



5100 West 12th Street, Sioux Falls, SD 57107-0514  
605-332-3200 PHONE + 605-332-1107 FAX  
WATS 800-328-1785

## EXHIBIT - BELT TRACKING, Hi Roller & Mini Roller Models

### SQUARENESS OF THE CONVEYOR

The complete conveyor trunking must be checked for straightness and squareness. This should have been done during the installation with a laser or wire to be sure the trunking was installed straight and square. The conveyor must be checked for cross level or twist. A hand held level must be placed exactly 90° from the centerline of the conveyor to assure that the conveyor is level and not twisted.

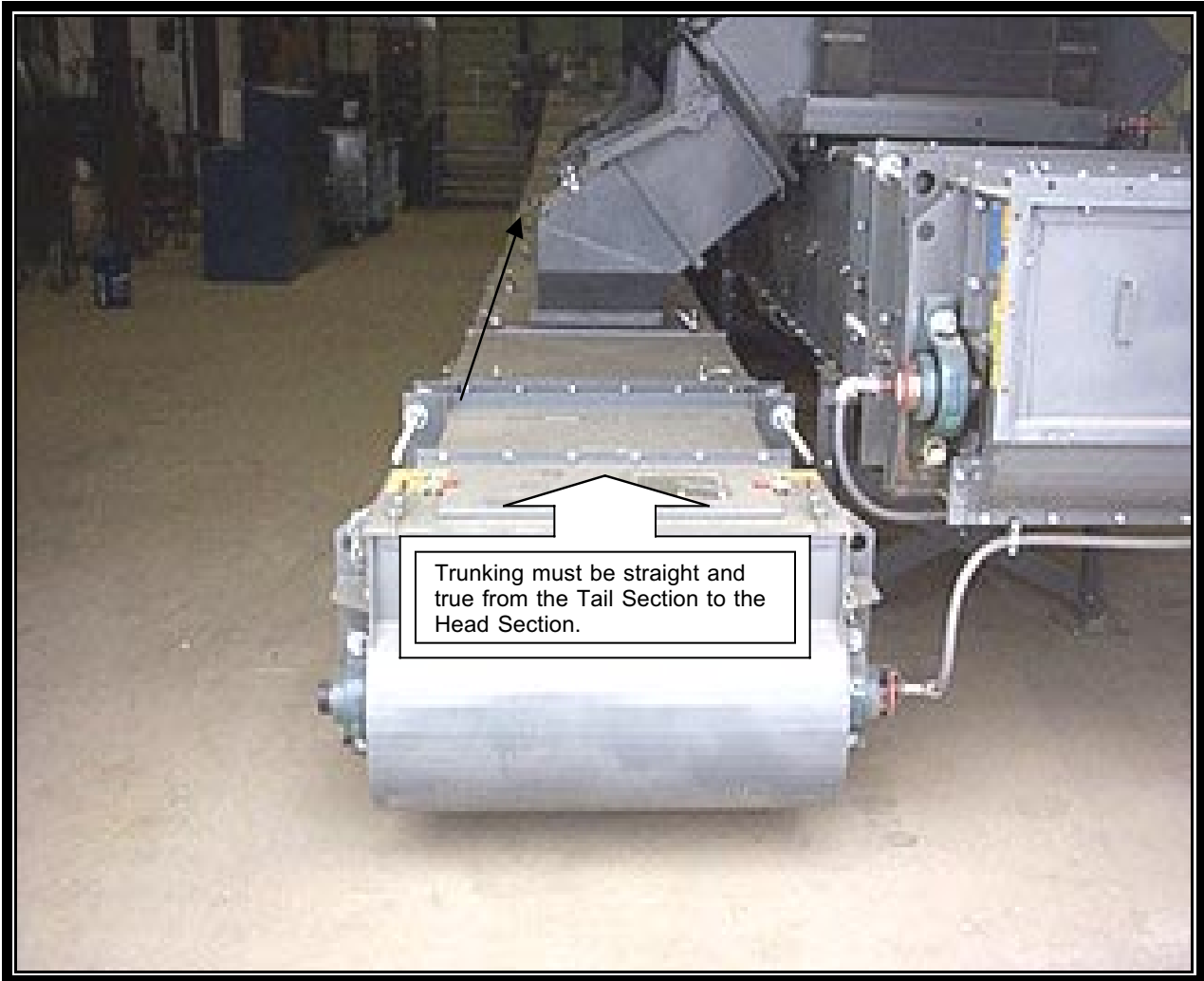

## IDLERS

Idlers must be checked to be sure that they have not become loose during shipping or installation. The Idlers must be centered and the setscrews tightened on the shafts. Setscrews holding the Idlers on the outside of the trunking must be checked for tightness. There are two pairs of setscrews on each Idler. These Setscrews are on the inside of the trunking holding the Stub Shafts on the Idler Roller. There is a Keeper Bolt on the end of each Stub Shaft as shown on page 4.

Setscrews:  
Idler Stub Shafts

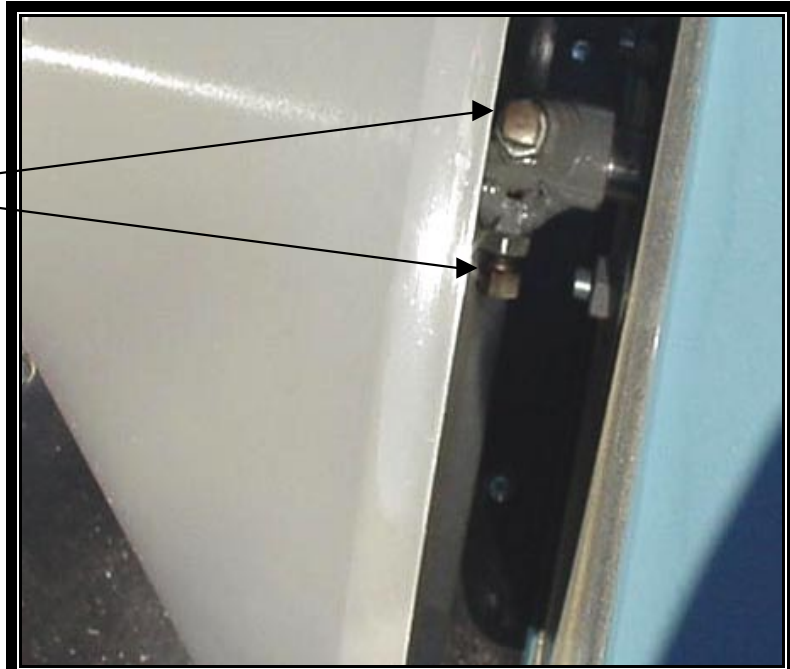

Spool Shaped  
Troughing Idlers

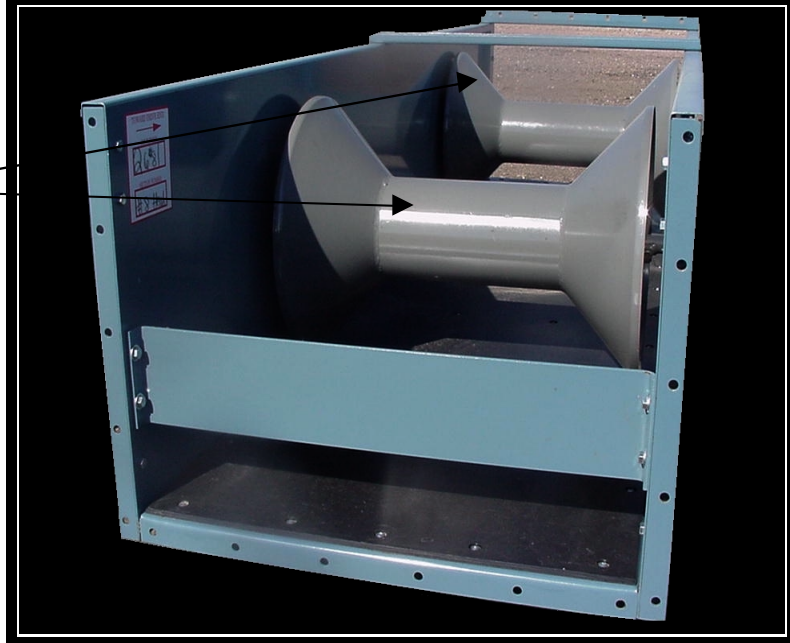

## BELT TRACKING - HEAD & TAIL

Belt tracking is adjusted at the Head & Tail Pulley by changing the position of the pulleys. This can be done by two different adjustments.

**TAIL:** First, the Tail Pulley can be adjusted to a limited degree to train the belt by using the belt tensioning Take-Up Rods. This adjustment is very limited to the amount of side slide in the telescoping Take-Up Boxes. Observe the belt tracking through the inspection door above the Tail Pulley. **Warning** Only observe the belt through the inspection door, do not place hands or tools through the opening.

**SIMPLE RULE:** If the belt runs to one side, tighten or extend that same side.

Second, the Head & Tail Pulleys can be adjusted by changing the number of Shims under each Bearing. Bearings on the Head & Tail Shafts have a Shim Pack. Belt Tracking can be adjusted by changing Shims.

**SIMPLE RULE:** As shown below, if the belt is tracking in the direction of “A”, the end of the pulley should be moved in the direction of “C” by removing a Shim. If the belt tracks to “B” side, the pulley end should be moved in the direction of “D” by removing a Shim. Opposite end and opposite direction adjustments can be made if required. Shims can be removed from one side and added to the other.

**NOTE:** It is important to allow the belt to make at least three full revolutions to determine where the belt is tracking before making adjustments.

**NOTE:** The addition of fine dust under and on top of the belt during the belt installation is very important. This material will minimize the stickiness of the belt and painted idlers.

**NOTE:** The belt must be operated empty and full for as long of time as possible before it is determined that Tracking Adjustments are required!

If pulley adjustments do not improve the belt tracking, only then should idlers be adjusted – ONLY if the conveyor is square; level; in-line; belt splice is square; belt is running on the flat part of the idler; and the load is centered.

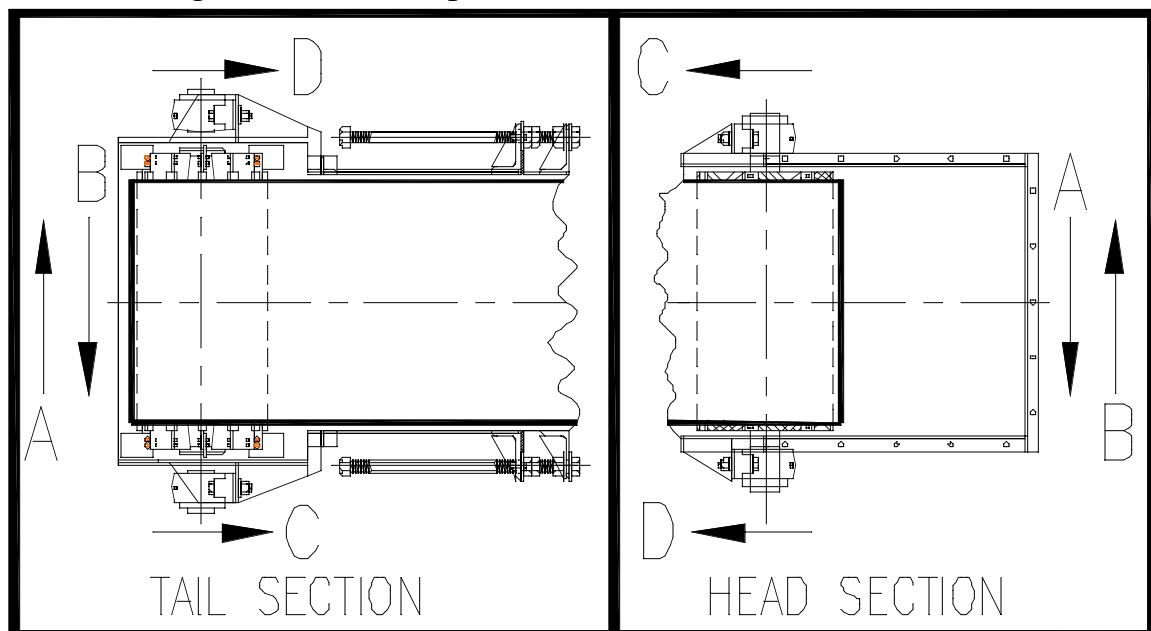

## BELT TRACKING – Hi Roller & Mini Roller Idlers

Idlers must be adjusted only if attempts to train the belt with the Head & Tail Pulleys has failed. The conveyor must be checked to be square; level; in-line; belt splice must be square; belt must be running on the flat part of the idler; and the load must be centered on the belt. All of these must check out before attempting the train the belt with the Idlers.

Hi Roller and Mini Roller Idler adjustments are completed by loosening the two Bearing Retainer Bolts. This should be done on bearing that is easiest to work on. These bolts hold the bearings in place and are located on both sides of the conveyor as shown below. The nuts on the inside of the conveyor are welded to a Nut Clip so that these nuts will not have to be held to loosen the bearing bolts. After loosening these bolts, the end of the Idler can be shifted either forward or backward.

Adjust a significant amount of Idlers in the middle of the conveyor, approximately 5 to 10 Idlers. Adjust these Idlers about  $\frac{1}{2}$ " to  $\frac{3}{8}$ ".

**SIMPLE RULE:** If the belt is too close to the side of the bearing being adjusted, move the bearing toward the Head Section. If the belt is too close to the opposite side, move the bearing toward the Tail Section.

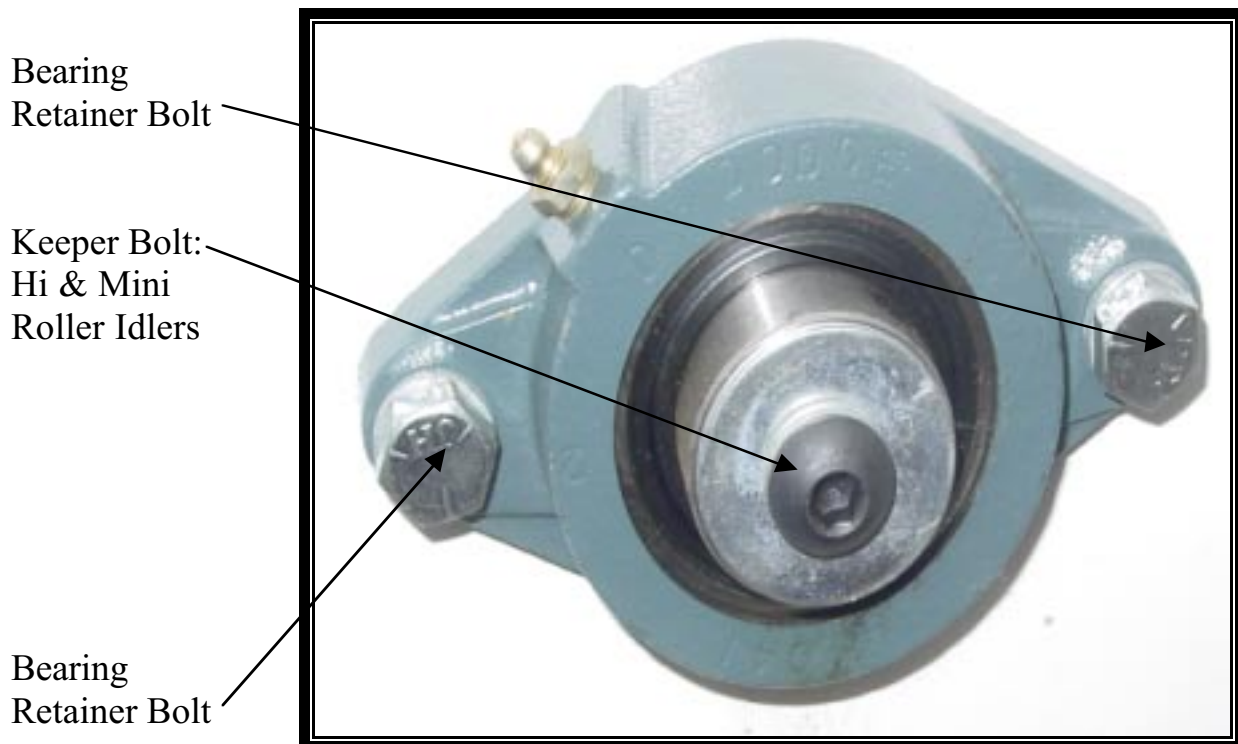

If the belt is tracking to the right in the conveyor, the end of the Idler should be shifted in “A” position. If the belt is tracking to the left, the end of the Idler should be shifted in “B” position. See the illustrations below. Remember, the belt will move toward the end of the idler that the belt first contacts.

NOTE: “Right” or “Left” is determined by standing at the Tail Section and looking toward the Head Section of the conveyor.

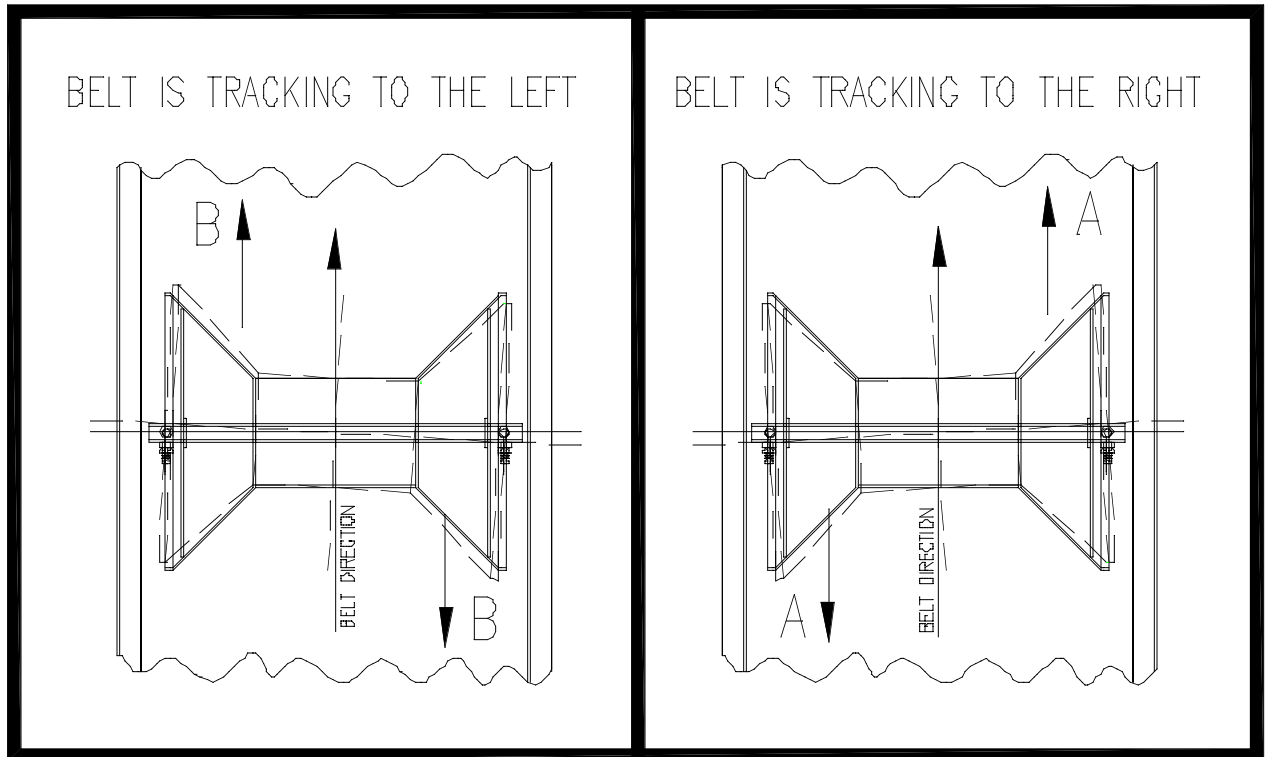

Test-run the conveyor both empty and properly loaded. Continue the training process until the desired training is achieved.

If adjusting the bearings on one side of the conveyor does not achieve proper training, repeat the procedure on the opposite side of the conveyor.

**If the belt will not train after all of these procedures; thoroughly check these items again - square, level, and straight in-line of the conveyor trunking, head and tail sections + belt splice must be square; belt must be running on the flat part of the idler; and the load must be centered on the belt.**

**If the belt will not train after all of the above checks and procedures, contact Hi Roller Conveyors.**

**If the belt trains significantly different properly loaded versus empty, contact Hi Roller Conveyors.**

If misalignment occurs when loading the belt, it can be caused by several problems:

1. The belt is being loaded off center. This must be corrected.
2. An internal bend called “Belt Camber” could exist in the belt. This is a belt defect. This condition must be checked with a special procedure. Contact Hi Roller Conveyors.
3. The belt has not been properly tensioned. This can be corrected easily by following the Belt Tension Procedure in this manual.
4. The belt has not yet stabilized. The belt and conveyor must be allowed to break-in or run-in over a period of at least one to two days of operation without a load.
5. The belt runs off center at or near the splice and then returns to the center after the splice has past. This condition is most likely caused by an improper splice installation. The splice may not be square! The belt will have to be spliced square and correctly by following the Belt Splicing Procedure in another Exhibit in this manual.
6. The belt runs out of alignment in an area away from the splice and then returns to the center. The area where the belt runs out of alignment must be inspected for cuts, burns, or other localized damage. Corrective measures must be taken to replace the defective section of belt.

BELT TRACKING – WITHOUT A LOAD = EMPTY

If misalignment occurs without a load on the belt, it can be caused by several problems:

1. The belt may not be contacting the center flat area of the idlers. This can be caused by a stiff belt. This must be corrected.
2. #2 to #6 above also apply to an empty belt.