



5100 West 12th Street, Sioux Falls, SD 57107-0514  
605-332-3200 PHONE + 605-332-1107 FAX  
WATS 800-328-1785

## EXHIBIT - Plug Detection Monitors

All Hi Roller Conveyors must have a Plug Detection Monitor installed properly in all Discharges. This includes single or multiple Discharge Spouts and Hoppers. Plugged Discharge Spouts or Hoppers must be detected immediately! The Plug Detection Monitor must then shut-down the conveyor immediately without any delay!

The location of the Plug Detection Monitor is very important. Hi Roller Conveyors typically uses a diaphragm-type switch. Shown below is Hi Roller Conveyors' typical Plug Detection Monitor (Monitor Manufacturing – Model GX) mounted in the side of the 90° Discharge Overshot. The monitor should be in lowest possible location away from the material flow off the end of the Head Pulley. The goal is to be able to detect a plugged condition as soon as absolutely possible. The switch must NOT be in the flow of the material. This is the same location shown on next page's drawing (Standard 90° Discharge-Plug Detection Monitor Location).



## Standard 90° Discharge – Plug Detection Monitor Location

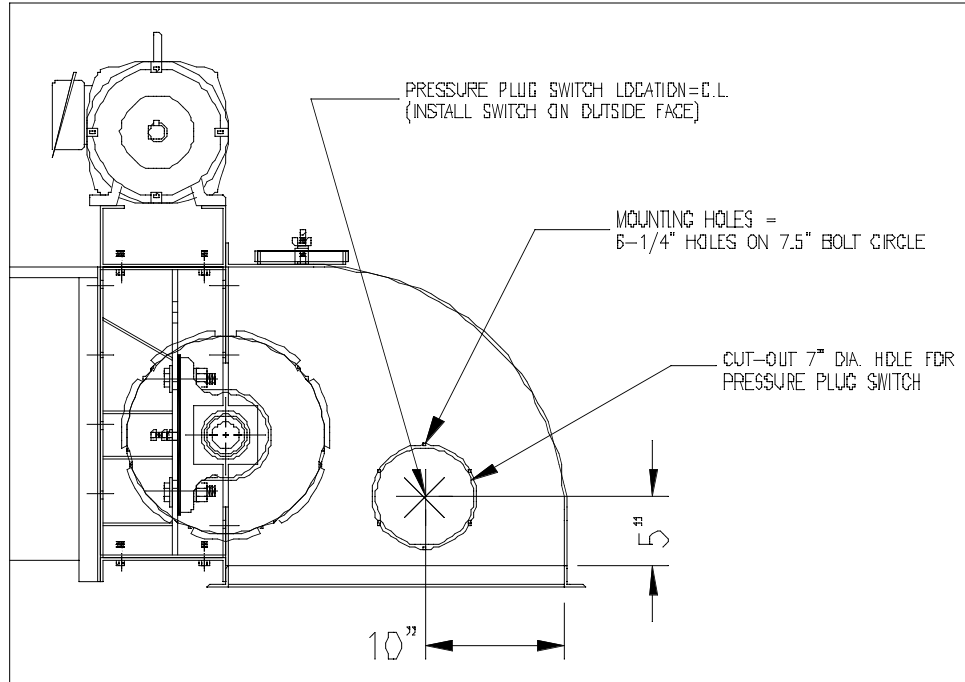

## 2-Way Discharge – Plug Detection Monitor Locations

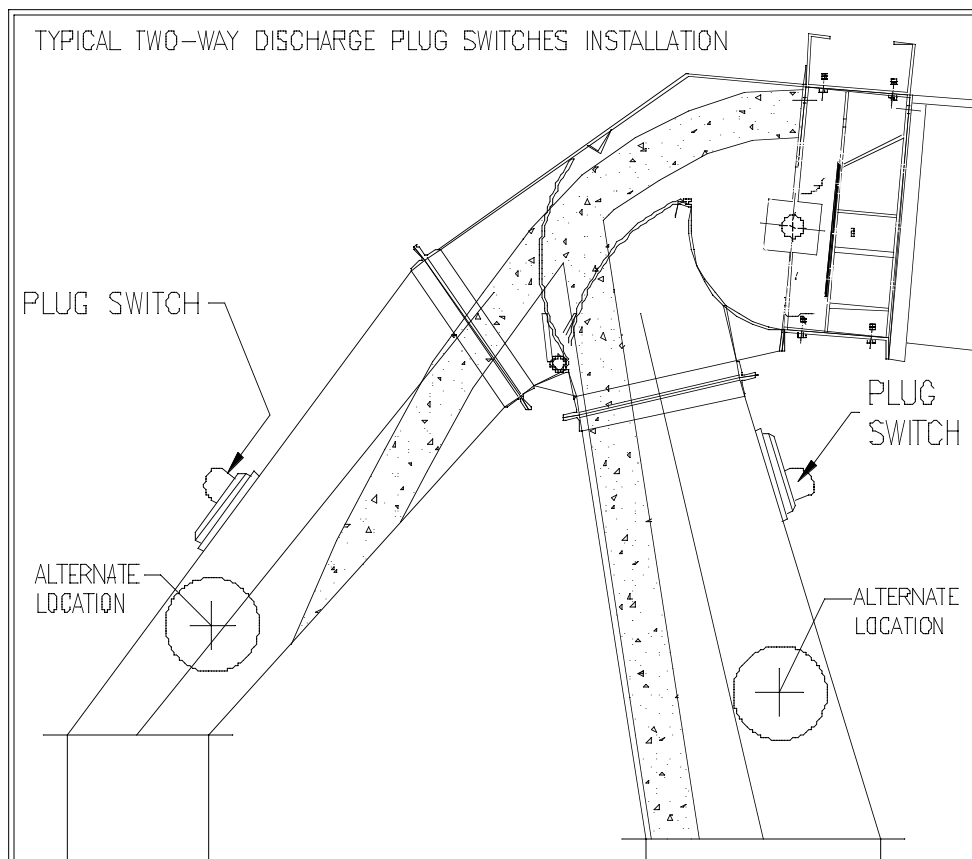

## Lo Profile Discharge – Plug Detection Monitor Locations

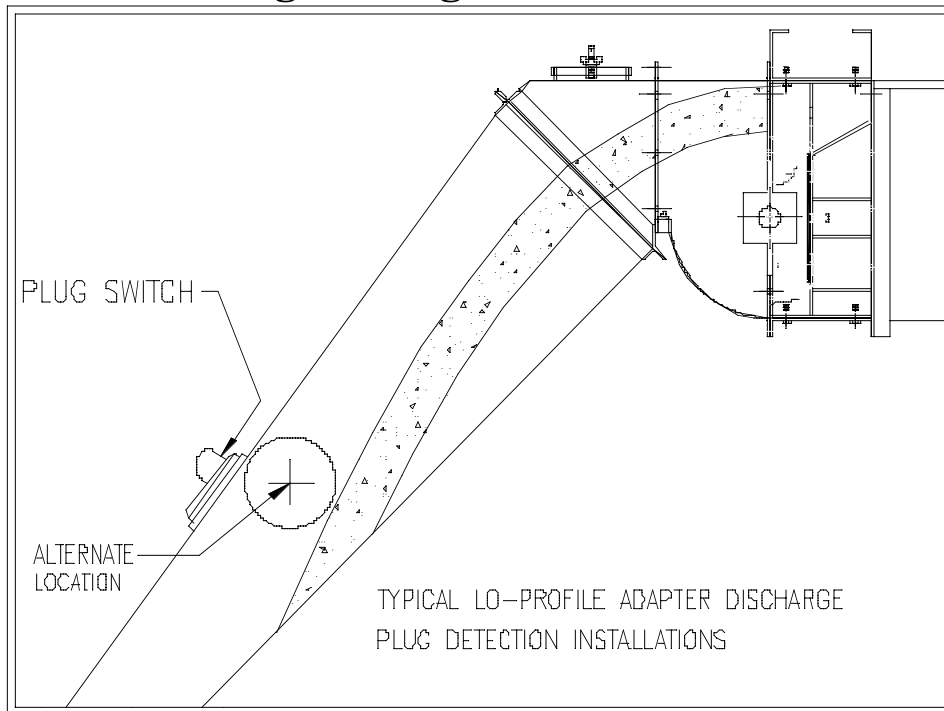

## Hopper Discharge – Plug Detection Monitor Locations

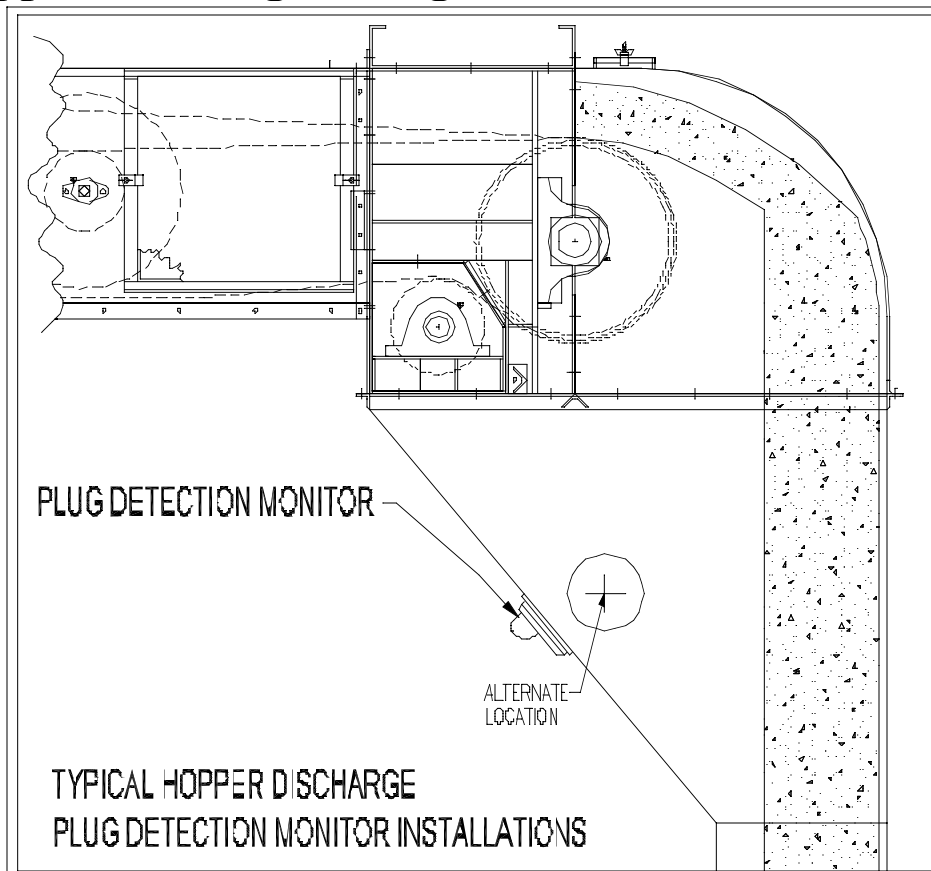

## Tripper Hopper Discharge – Plug Detection Monitor Location

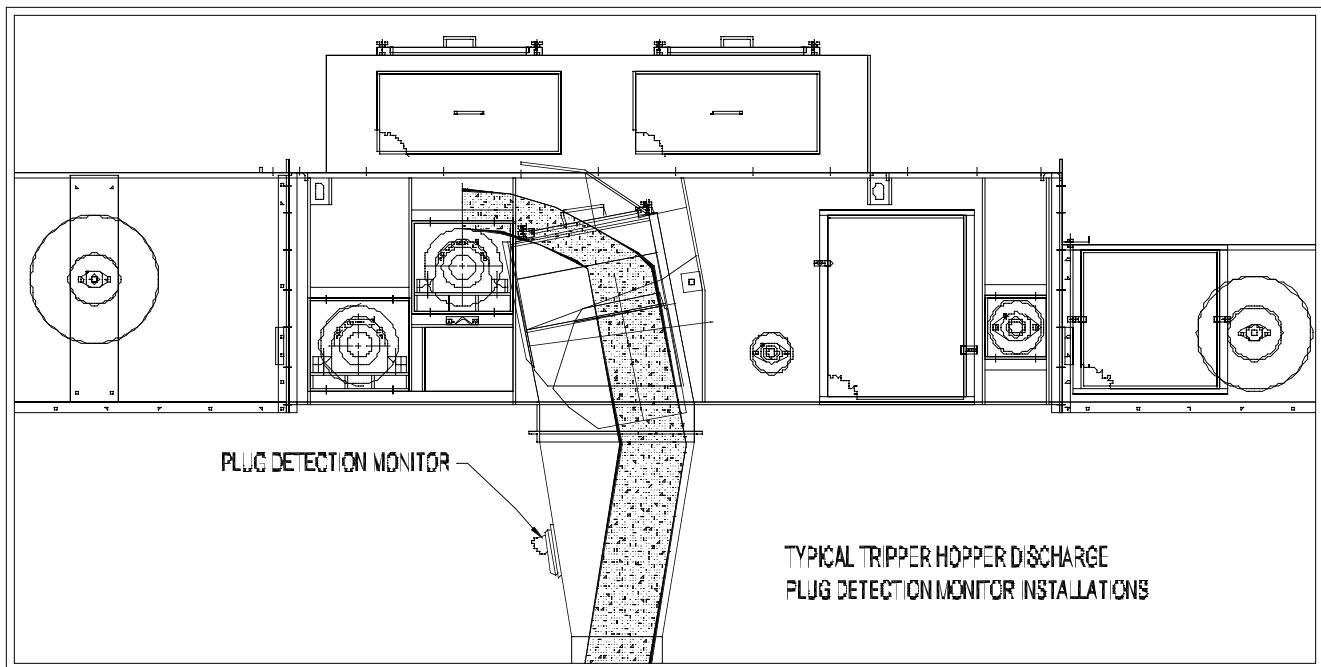

All Hi Roller Conveyors must have a Plug Detection Monitor installed properly in all single or multiple discharges. Plugged Discharge Spouts or Hoppers must be detected immediately! The Plug Detection Monitor must then shut-down the conveyor immediately without any delay!

Hi Roller Conveyors should be contacted with any further questions or required information.

5100 West 12th Street  
Sioux Falls, SD 57107-0514  
605-332-3200 PHONE  
605-332-1107 FAX  
WATS 800-328-1785  
[www.hiroller.com](http://www.hiroller.com)  
email – [sales@hiroller.com](mailto:sales@hiroller.com)