

Mini & Lo Roller

Models 16 through 36

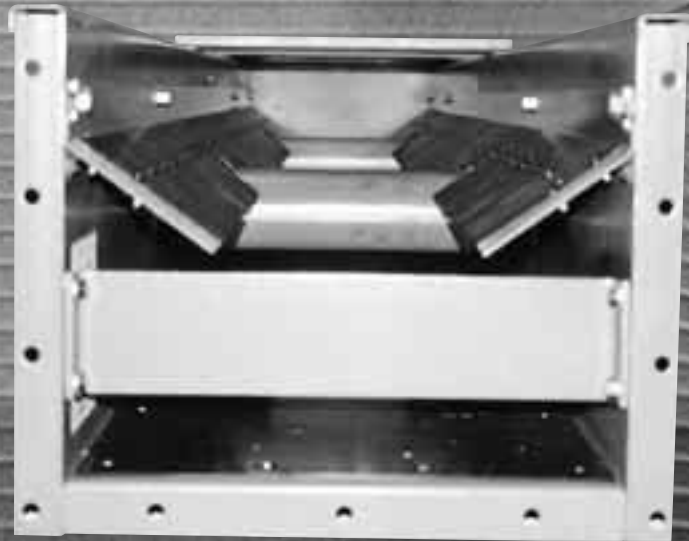
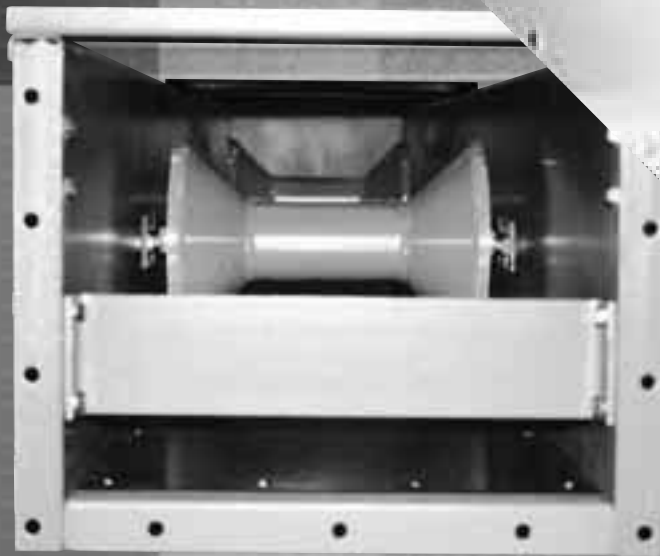

Invest

in

efficiency.

HI ROLLER[®]
ENCLOSED BELT CONVEYORS

The Problem Solver

Hi Roller Enclosed Belt Conveyors are designed for the safe, gentle, and efficient handling of dry, bulk materials. This unique, totally enclosed belt conveyor contains dust and spilled material *and* automatically reloads that material back on to the belt.

The arrow shows the flow of dust and spilled material back to the tail section where it is directed into reloading vanes, then thrown and deflected back on to the top belt.

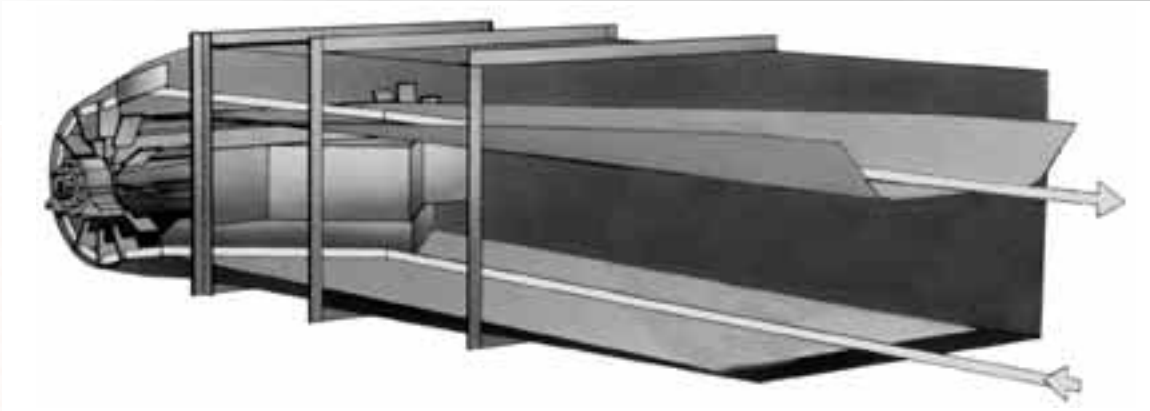

Hi Roller Enclosed Belt Conveyors are heavy duty, low maintenance, safe, gentle, and efficient. Hi Roller uses unique idlers which allow all bearings to be isolated from internal dust and contaminants. Internally, the troughing belt gently conveys bulk materials to the discharge point. The returning belt slides over an antistatic return liner and continually wipes the bottom enclosure clean of any dust or spilled material. The patented reloading system is the key to a successful system. The absence of this feature can cause product build up, plugging, costly wear, and downtime.

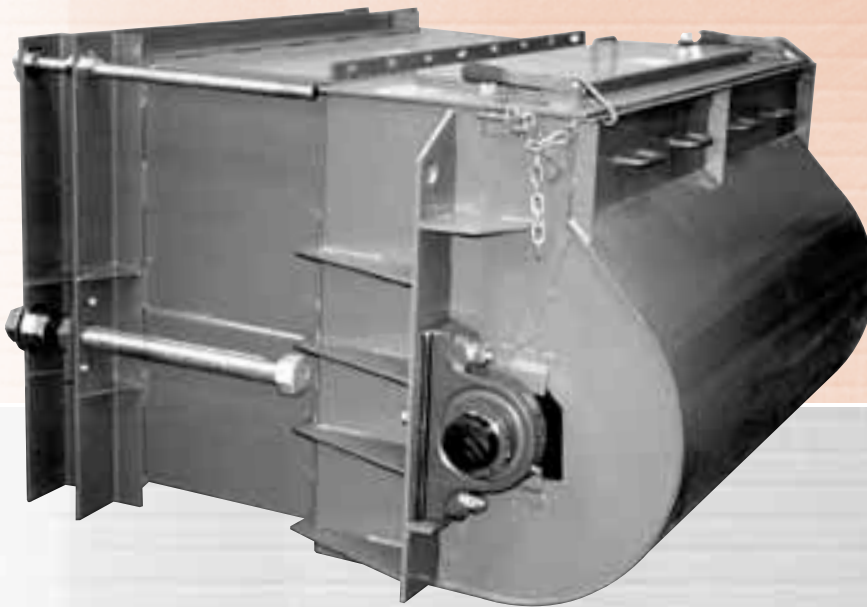

The heavy duty tail section incorporates a gasketed sliding box take-up with tensioning and leveling rods. The tail shaft is supported by external pillow block spherical roller bearings. The tail shroud splits at the shaft so that the pulley can be removed without cutting the belt. The shroud comes complete with safety chains and can be removed without the use of tools.



Internally, the spiral winged tail pulley provides constant belt contact for extended belt life. The patented reloading system includes a rugged plow, reloading flippers and a stationary deflector.

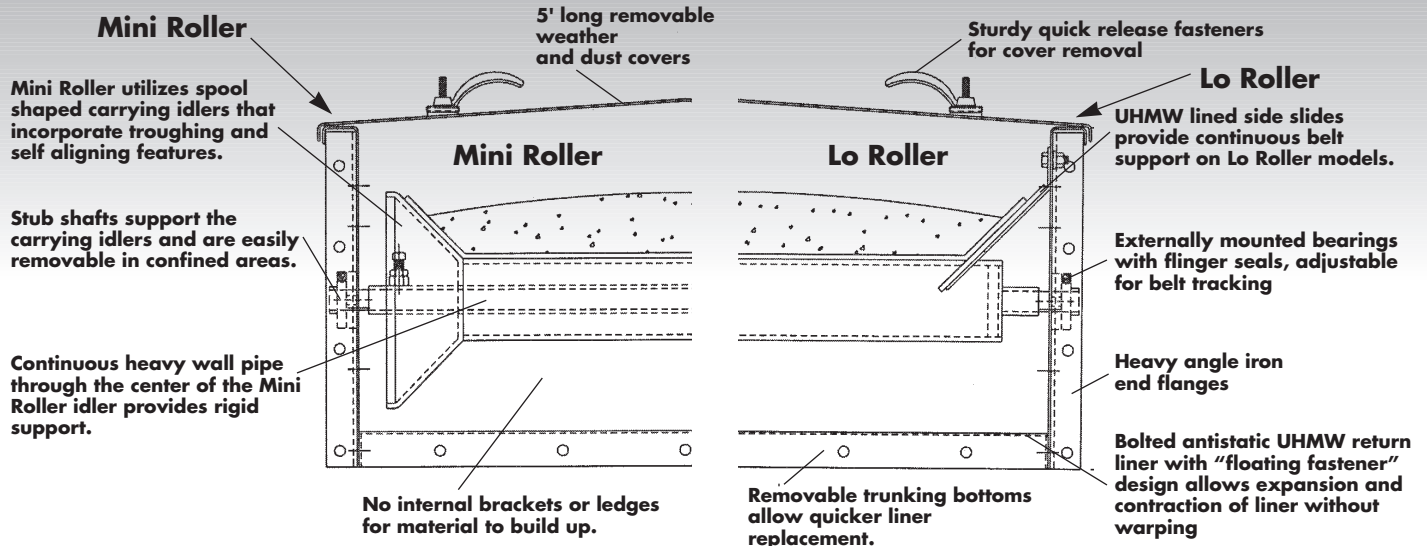

M I N I R O L L E R C A P A C I T I E S

		BELT SPEED IN FEET PER MINUTE							
MODEL	UNITS	350	400	450	500	550	600	650	700
16	BU/HR	2,489	2,845	3,200	3,556	3,911	4,267	4,623	4,978
	CF/HR	3,099	3,542	3,984	4,427	4,870	5,313	5,755	6,198
	MTPH	67	77	87	96	106	116	125	135
20	BU/HR	3,734	4,267	4,800	5,334	5,867	6,401	6,934	7,467
	CF/HR	4,648	5,313	5,977	6,641	7,305	7,969	8,633	9,297
	MTPH	101	116	130	145	159	173	188	202
24	BU/HR	5,088	5,815	6,542	7,269	7,996	8,722	9,449	10,176
	CF/HR	6,335	7,240	8,145	9,049	9,954	10,859	11,764	12,669
	MTPH	138	158	177	197	217	236	256	276
30	BU/HR	7,321	8,367	9,413	10,459	11,504	12,550	13,596	14,642
	CF/HR	9,115	10,417	11,719	13,021	14,323	15,625	16,927	18,229
	MTPH	198	227	255	283	312	340	368	397
36	BU/HR	9,795	11,195	12,594	13,993	15,393	16,792	18,192	19,591
	CF/HR	12,195	13,938	15,680	17,422	19,164	20,906	22,648	24,391
	MTPH	265	303	341	379	417	455	493	531

L O R O L L E R C A P A C I T I E S

		BELT SPEED IN FEET PER MINUTE							
MODEL	UNITS	350	400	450	500	550	600	650	700
16	BU/HR	1,984	2,267	2,551	2,834	3,118	3,401	3,685	3,968
	CF/HR	2,470	2,823	3,176	3,529	3,882	4,234	4,587	4,940
	MTPH	54	61	69	77	84	92	100	108
20	BU/HR	4,257	4,886	5,497	6,108	6,719	7,329	7,940	8,551
	CF/HR	5,323	6,083	6,844	7,604	8,365	9,125	9,885	10,646
	MTPH	116	132	149	166	182	199	215	232
24	BU/HR	5,696	6,509	7,323	8,137	8,950	9,764	10,578	11,391
	CF/HR	7,091	8,104	9,117	10,130	11,143	12,156	13,169	14,182
	MTPH	154	176	198	221	243	265	287	309
30	BU/HR	8,031	9,178	10,326	11,473	12,620	13,768	14,915	16,062
	CF/HR	9,999	11,427	12,855	14,284	15,712	17,141	18,569	19,997
	MTPH	218	249	280	311	342	373	404	435
36	BU/HR	10,615	12,132	13,648	15,165	16,681	18,198	19,714	21,231
	CF/HR	13,216	15,104	16,992	18,880	20,768	22,656	24,544	26,432
	MTPH	288	329	370	411	452	493	534	575

FPM = Feet Per Minute BPH = Bushels Per Hour CFPH = Cubic Feet Per Hour MTPH = Metric Ton Per Hour (Based upon 769 Kg per cubic meter)

Capacities are based upon horizontal installation and even belt loading.

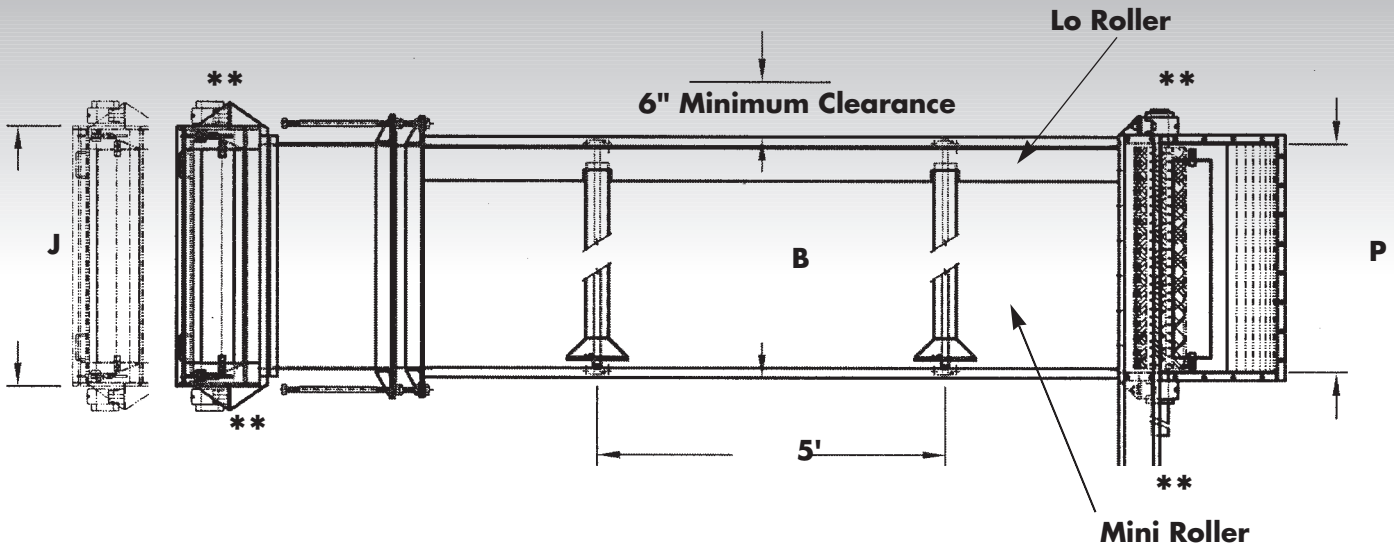

**Overall width determined by bearing and drive size.

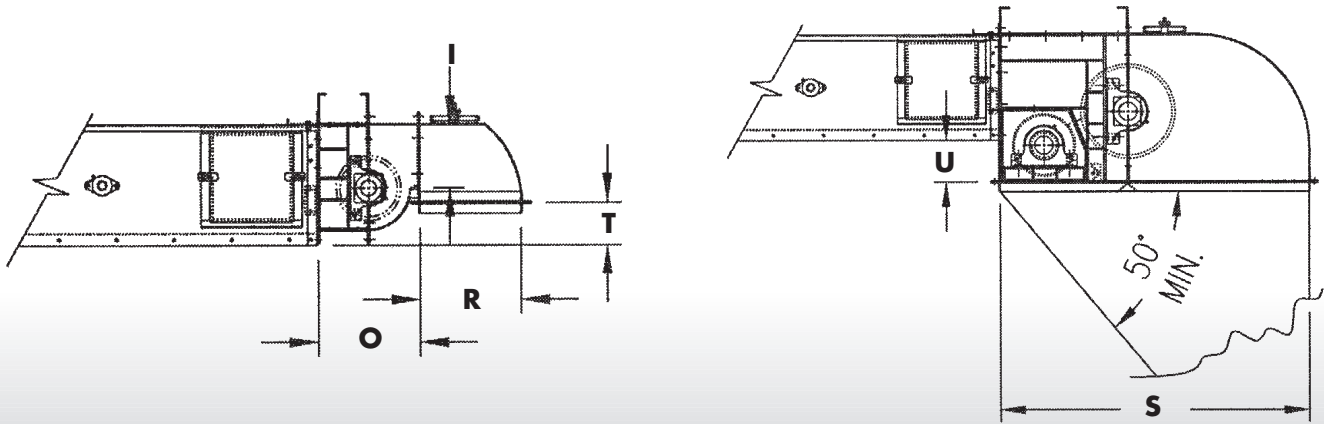
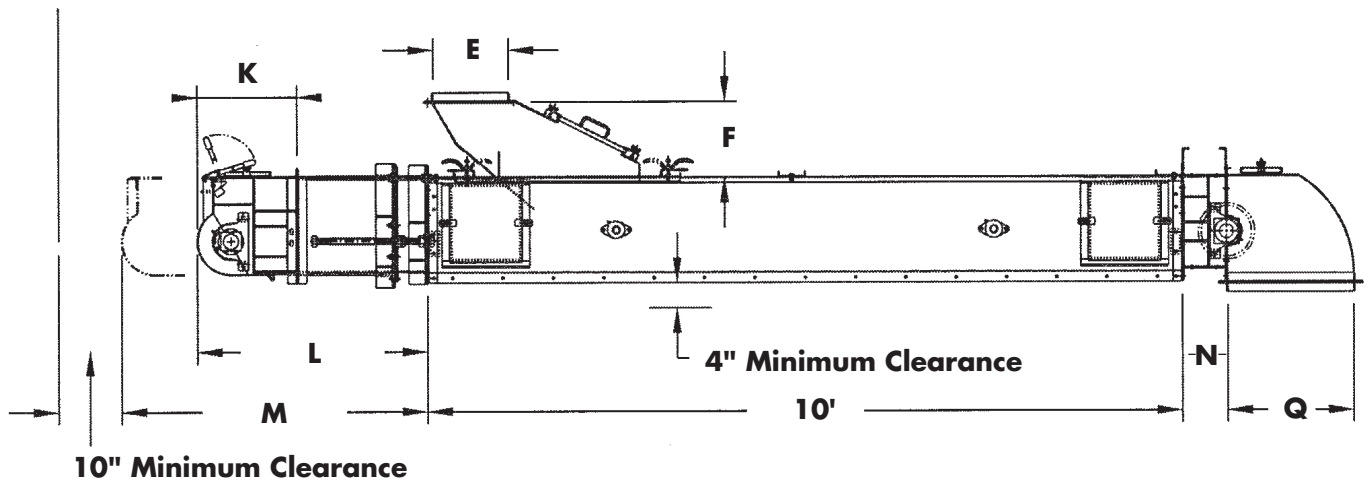

Mini Roller

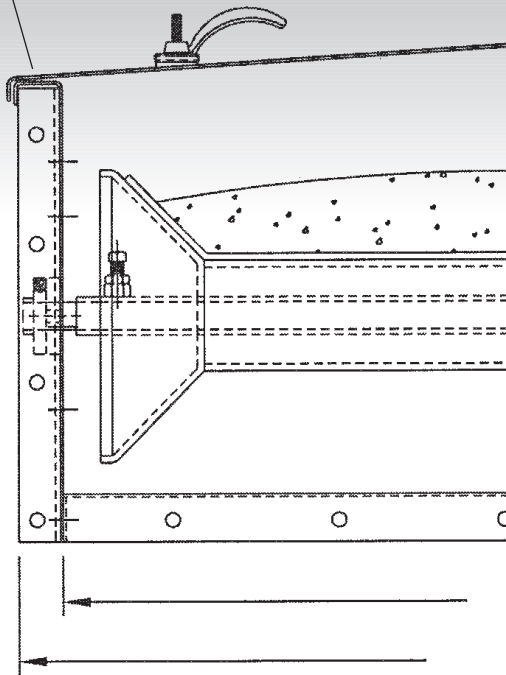

Lo Roller

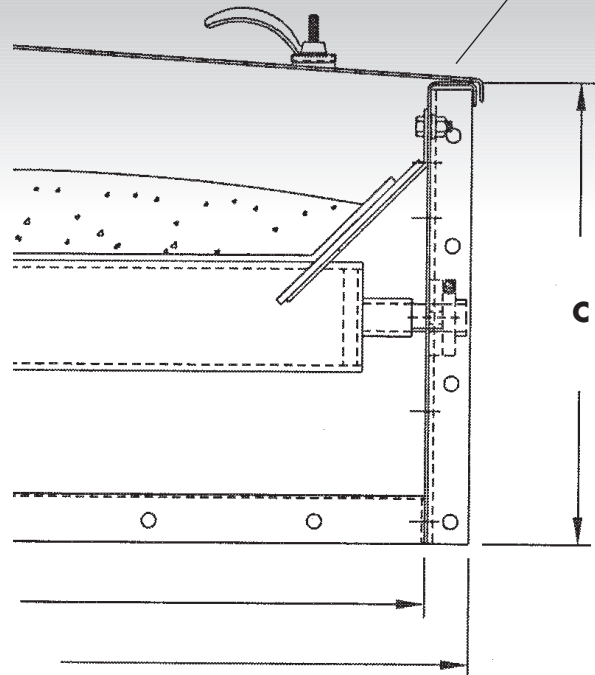

MINI AND LO ROLLER DIMENSIONS

SPECIFICATIONS		LO AND MINI MODELS				
	DESCRIPTIONS	16	20	24	30	36
A	Trunking Width (inside)	18	22	26	32	38
B	Trunking Width (outside)	21½	25½	29½	35½	41½
C	Trunking Height (outside)	16¾	16¾	16¾	16¾	16¾
D	Inlet Opening Width	6	10	14	20	26
E	Inlet Opening Length	12	12	12	12	12
F	Standard Inlet Height	12	12	12	12	12
G	Cleanout Inlet Height	1¾	1¾	1¾	1¾	1¾
H	Inlet Cover Length	36	36	36	36	36
I	Lo Profile Opening Height	8¾	8¾	8¾	8¾	8¾
J	Tail Width (less bearings)	25½	29½	33½	39½	45½
K	Stub Tail Length	15¾	15¾	15¾	15¾	15¾
L	Take-up Length Retracted	Take-up Length + 24"				
M	Take-up Length Extended	Take-up Length x 2 + 24"				
N	Standard Head Length	7	7	7	7	7
O	Lo Profile Head Length	14	14	14	14	14
P	Discharge Opening Width	19¾	23¾	27¾	33¾	39¾
Q	90 Degree Discharge Length	20	20	20	20	20
R	Lo Profile Discharge Length	14	14	14	14	14
S	Snubber Discharge Length	48"	48"	48"	48"	48"
T	Discharge to Trunking Bottom	6	6	6	6	6
U	Discharge to Trunking Bottom	6¾"	6¾"	6¾"	6¾"	6¾"

The above dimensions are stated in inches.

Designs and specifications are subject to change without notice.

Hi Roller Conveyors are manufactured under several Patents and Pending Patents.

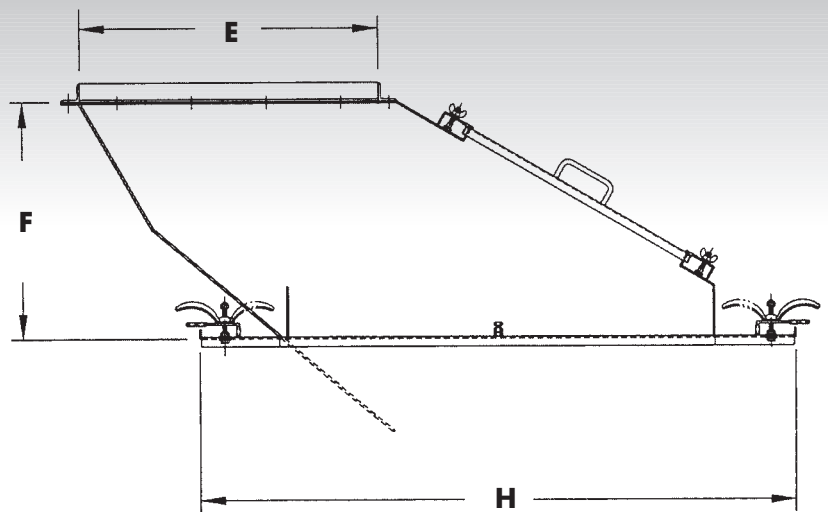
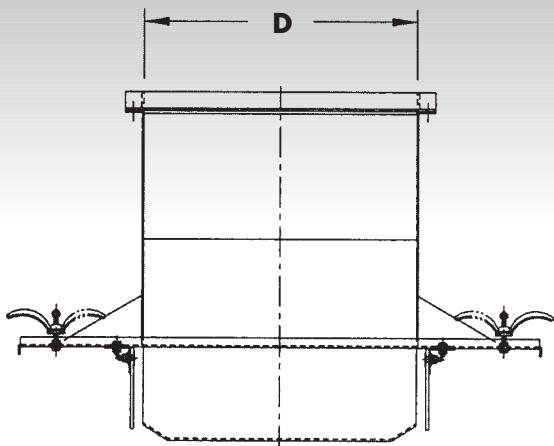

Above: Typical initial inlet with fixed skirts

Below: Typical cleanout inlet with swing-down skirts

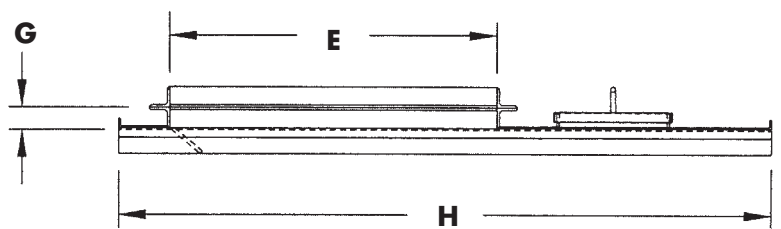
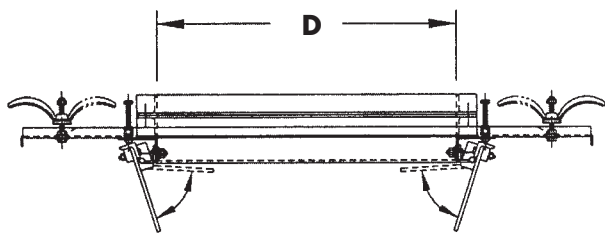

Inlet heights and lengths can be customized to your specific applications.

The Mini Roller and Lo Roller conveyors provide you with two options for lower profile, lower capacity conveying. The unique spool shaped idler used in the Mini Roller provides a troughed support for the conveyor belt. The spool shaped idler uses two external bearings as opposed to six internal bearings on more conventional idlers. Alternatively, the Lo Roller utilizes flat idlers for belt load support and UHMW lined side slides for belt edge support. This design provides a continuous seal along the belt edge for the entire length of the conveyor.

The Mini Roller idler is constructed with a heavy wall pipe that passes through the center of the idler. This provides rigid support. The center pipe is then reamed to just the right tolerance to accept the turned and polished stub shaft that passes through the external bearings.

The Lo Roller idler is constructed with an integral shaft as opposed to the stub shaft design. This idler can be removed by simply dropping the idler inside the enclosure and raising the belt edge to permit removal through the top of the conveyor.

Features & Options

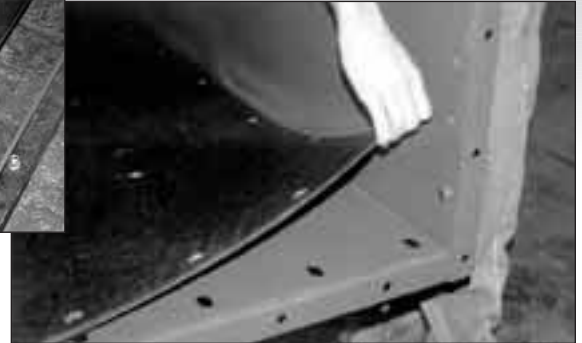
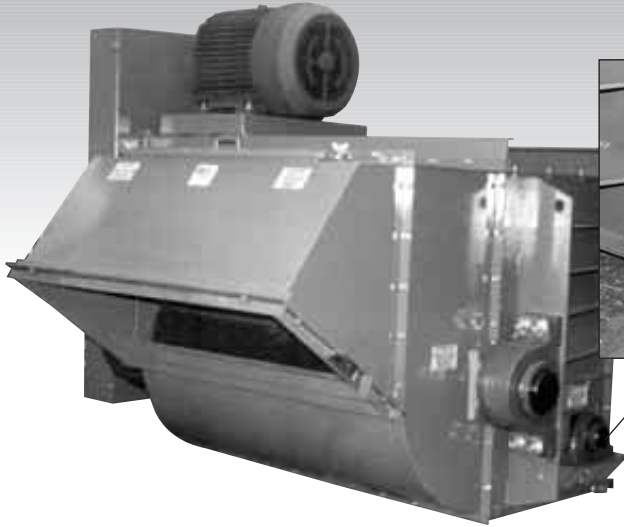

Shown is a Snubber head with a Lo Profile Adapter and 45 Degree Discharge. Head Sections split at the shaft so that the pulley and shaft can be removed without cutting the belt. Snubber pulleys are also mounted in a removable framework.

Return liner is pattern punched and countersunk. The slotted bottom pan allows for expansion and contraction of the bottom liner. The slots also assure that replacement liner sent from the factory will match the existing hole pattern.

- Gradual Inclines
- Sharp Upbends
- Intermediate Discharge Trippers
- Enclosed Movable Trippers
- Reversing and Reloading in both directions
- Built-in Two Way Discharges
- Bi-Directional Inlets
- Internal Gravity Take-ups
- Galvanized Exterior Housing

- Stainless Steel Exterior Housing
- Metric Components
- Outboard Bearing Mounts with Shaft Seals
- Intermediate Sidewall Inspection Doors
- Support Legs
- Integrated Truss and Walkways
- High Span Trunking
- Abrasion Resistant Bottom Liners
- Belt Scales

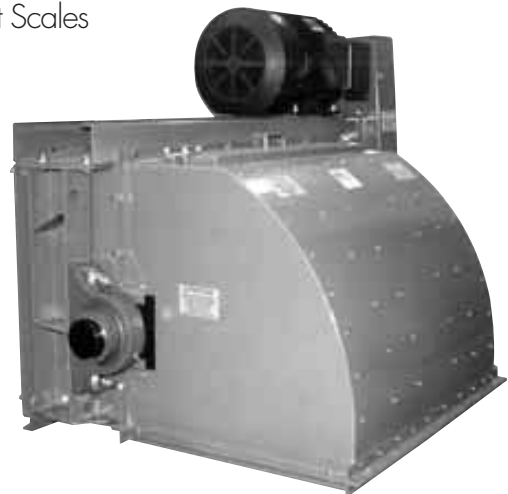
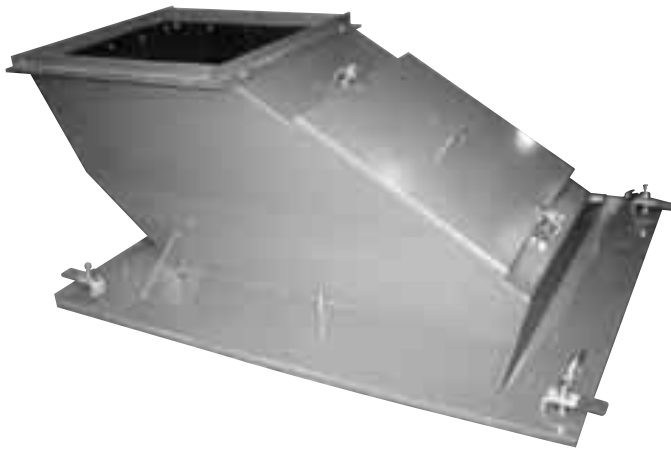

Inlets are designed to direct the material with the travel of the belt. Counterweighted swing down skirts on intermediate inlets come down with the weight of the product and automatically retract as product stream stops. Multiple Inlets can be used at the same time. Inlet liners can be replaced through the large inspection doors.

Shown is a Standard head with a 90 Degree Discharge. Head Bearings are easily adjustable for belt tracking. All inlets and discharges are supplied with matching flanges.

Hi Roller is more than a manufacturer. We can review your project on-site, make recommendations, prepare proposal drawings, and provide start-up assistance. We have found that a successful installation relies upon a clear understanding of the process, from the spouting and placement of the material on to the belt to the discharge and spouting out the other end. Put our design experience to work for you.

Product Line

Hi Roller Conveyors are custom built to your specific requirements. Some of our more popular models include:

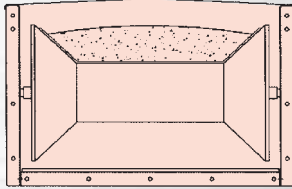

Hi Roller: Available in belt widths from 18" to 60," this is our original and most popular model. The unique bell-shaped carrying idler provides the trough for the belt and utilizes two external bearings as opposed to the six internal bearings associated with a conventional idler. The bell-shaped idler also has built-in self-aligning characteristics for both single and bi-directional conveyors.

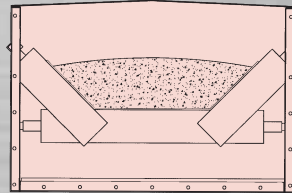

Hi Life: Available in belt widths from 18" to 72", the Hi Life utilizes possibly the heaviest, longest life, most reliable conveyor idler available. Resembling a conventional conveyor idler, the Hi Life idler is much thicker, the bearings are much larger *and* there are no brackets or bearings exposed to the internal atmosphere of the conveyor housing.

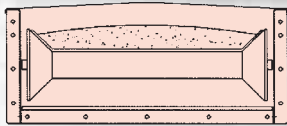

Mini Roller: Available in belt widths from 16" to 36", the Mini Roller includes all the benefits of the Hi Roller in a lower profile design.

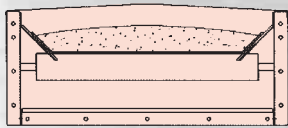

Lo Roller: Available in belt widths from 16" to 36", the Low Roller utilizes a flat carrying idler to support the loaded weight of the belt and relies on the UHMW side slides to form a trough for the belt. This design provides continuous belt support and creates a seal at the edges.

Specials: Tailored to your specific application, we can customize conveyors such as the V Roller (two idlers mounted in a V configuration), Hi Bulk (an enmasse belt conveyor designed to move large quantities of material in limited space), Hi Lift (a steeply inclined conveyor utilizing cleats or buckets fastened to the belt). The Consignor is a belt conveyor with a totally enclosed, moveable discharge tripper to discharge material off at any location along the conveyor. We can also supply you with an integrated catwalk and walkway for longer spans between supports.

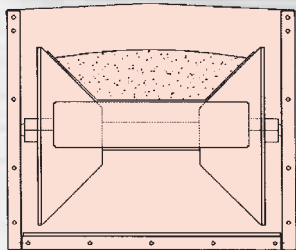

Super Roller: Available in belt widths from 36" and up, the Super Roller combines a larger bell-shaped idler and a flat idler turning independently. This design provides a deeper trough than the Hi Roller Conveyor and reduces the slippage between the belt and the idler.

HI ROLLER®
ENCLOSED BELT CONVEYORS

5100 West 12th Street
Sioux Falls, South Dakota 57107-0514 USA
Phone: (605) 332-3200
Toll Free (US and Canada): 800-328-1785
Fax: (605) 332-1107
E-Mail: sales@hiroller.com
Website: www.hiroller.com

Belt
Conveyors
have long
been known
as the
most
gentle,
efficient and
durable means
of conveying
materials.